

'V' Notch Segmented **Ball Valve** with
Intelligent **Electrical Actuator**

KRISS

Basis Weight Valve **1550SERIES**



YES WE CARE



KRISS Offers V-Notch Segmented Ball Valve With Single Phase Linear Electric Actuator

Index

Basis Weight Valve

Introduction	01
Application	02
Features & Advantages - Valve	03
Specifications - Valve	03
Features & Advantages - Actuator	04
Specifications - Actuator	04
Specifications of Control Panel	05
General Arrangement of Test Bed for Testing of Valve	05
Flow Capacities & Characteristics	06
'V' Notch Segmented Ball Valve Shaft Downstream	06
Part List - 'V' Notch Ball Valve	07
Exploded View 'V' Notch Ball Valve	08
Pressure - Temperature Ratings	08
Constructional View of Intelligenet Electrical Actuator	09
Overall Dimensions of 'V' Notch Segmented Ball Valve with Intelligenet Electrical Actuator	10

Segmented Ball valve is a ball sector valve with metal to metal or metal to PTFE seating. The segmented ball valve combines the best control characteristic of the ball valve and the butterfly valve. It can be used both as a control valve and as a shut off valve. It is available as standard in Stainless steel. It is also available in other materials based on the application.

V-Notch Ball Valve Features

- A one piece, leak proof stainless steel body, with face to face lengths in acc. with IEC standards
- A ball sector with top and bottom bearings for low operating torque so that low torque actuators can be used
- A 'V' shaped sector that provides accurate control over a wide range, even at low flow rates and if used for viscous media with high concentrations of solid particles.
- A spherical area of the ball sector which, with PTFE seat gives tight closing. The stellite seat ring ensures excellent tightness at all differential pressures. The maximum leakage in the direction of flow is less than 5×10^{-6} of the Kv value in this case.
- Metaloplast bearings
- O ring or graphite packing for the stem gland
- The standard stellite seat can easily be converted to PTFE after turning the ball sector by 180 degrees, without the need to dismantle the valve.
- Are designed to over come the problems of harsh, particle entrained processes.



Applications



Segmented Ball valve can be used both as a control valve and as a shut off valve in a wide variety of applications and in different operating modes. The valve represents a concrete result of our product philosophy which is focused on functionality, high quality and low life cycle cost and is based on concentrating our range to a limited number for valve types, but all of them suitable for a wide variety of applications. One of the most successful area for this valves is Paper Industries where they are used for Paper grammage Control application.

Segmented Ball valve addresses and solves many long standing challenges faced by traditional ball valves such as:

- Piping forces that unevenly load the seal
- Low range ability due to limited orifice characterization
- Unsatisfactory shutoff capabilities
- Achieves Class IV shut off with a metal seal and Class VI with the special soft seal.

The excellent control characteristics of segmented Ball valve are particularly beneficial under severe control conditions, in difficult media and under demanding pressure conditions in the process industry such as

- if the media contains solid particles
- if a wide control range is required
- if control applications involving high pressure drops
- if cavitations occurs
- or for corrosive applications



Features & Advantages of **V-Notch Ball Valve**

Features

Advantages

One piece body	:	High performance ensured regardless of flange torque Loads, seal tightness not altered by piping forces, as in Two-piece bodies, one leak path eliminated
Segmented 'V' notch ball	:	Clogging reduced, 'V' shaped orifice exceeds 300:1 Range ability, excellent shearing action in fibrous fluid Mediums
Pressure assisted / bi-Directional special Seal	:	Metal seal provides greater than ANSI Class IV shutoff soft seals achieve ANSI Class VI shutoff
Self-centering seal	:	Seal installation improved and simplified, shutoff further Improved
Thick walled retainer	:	Valves normal service life extended in erosive environments
Flangeless design standard	:	Reduced cost
Separable flange option	:	Bolt length reduced, avoiding bolt stretch and leakage in event of fire
Integral flange option	:	Bolt length reduced, avoiding bolt stretch and leakage in event of fire
Interchangeability	:	Standard face to face dimensions allow for easy field Retrofitting of other manufacturers product lines.
Seal replaceable without removing ball and shaft	:	Maintenance is fast and easy
Shaft serviceable from Outboard end of ball [3-12, 16" only]	:	The need for actuator removal to replace ball and shaft is eliminated, shaft protected from blow out.
Full, uninterrupted Gasket surface	:	Gasket alignment problems reduced, wider range of gasketing possible including spiral wound

Specifications of V-Notch Ball Valve

SIZE	:	Ranging from 2" to 20"
TYPE OF CONSTRUCTION	:	'V' Notch shear stream
DESIGN	:	Ball type control valve
END CONNECTION	:	Flangeless, also available in Flanged connection
END PLUG	:	S.S.316
END SEAL	:	Graphite
MATERIAL OF CONSTRUCTION	:	S.S.316
BALL MATERIAL	:	Chrome plated SS317
SHAFT MATERIAL	:	17-5 PH
SEAT MATERIAL	:	Filled PTFE
RETAINER MATERIAL	:	Chrome plated SS316
PACKING MATERIAL	:	PTFE 'V' ring
LEAKAGE CLASS	:	Tight shut off Class VI
WORKING PRESSURE	:	4 Bar
BALL PRESSURE CLASS	:	150 – 300 Class
TEMPERATURE	:	Ambient
CHARACTERISTIC	:	Linear or modified equal percentage
FITTED WITH	:	Intelligent Single Phase Electrical Reversible Stavout type Linear Actuator. Supply voltage: 230 V AC

Features & Advantages of Intelligent Actuator

Features

- Very high stiffness [self-locking]
- Consistent closing force due to internal disc springs
- Flexible mounting position [apart from downwards]
- Silent and jerk less operation
- Hand wheel for the start up / or emergency cases
- Impact and corrosion resistant housing with high grade aluminum
- Wide range of applications
- Robust construction
- Great variety of common accessories, such as
 - Positioner [Input signal 4-20mA, 0-10 V DC]
 - Adjustable limit switches
 - Potentiometer for position feedback
 - Stroke transmitter [standard signal 4-20mA]
 - Space heater for low ambient temperature
- Control device for fail-safe position in case of power failure

Advantages

Actuator Model No.	2000-200-S	2000-600-S
Suitable for Sizes	50-150mm	200-500mm
Opening time	280 sec/90 degree	306 sec/90 degree
Closing time	280 sec/90 degree	306 sec/90 degree
Torque developed	120 Nm	375 Nm
Degree of protection	IP55	IP55
Standard pulse width	0.008 sec	0.008 sec
Resolution	35000 steps	40000 steps
Input signal	230 V AC Pulse Input	230 V AC Pulse Input
Motor type	Non-blocking stall duty	Non-blocking stall duty
Supply voltage	230 V AC	230 V AC
Rating	3.14W	16.0 W
Class of Insulation	'B'	'E'

Specifications of Intelligent Actuator

The Linear actuator meets all major requirements of Paper Industries, used for continuous regulating services. Both force & travel are widely adjustable in order to avoid any over stress and damage to the V notch ball valve, particularly to the valve shaft. The actuators themselves are designed to with stand the maximum pushing force without any damage.

- Excellent positioning accuracy
- Long service life and high reliability
- Adjustable valve travels

Specifications of Control Panel

- Main On/Off switch [MCB]
- Auto / Manual switch
- Micro processor based pulse convertor
- Current source
- 4-20 mA Feed back Output
- Provision for Run Mode / Test Mode selection – under test mode valve will operate through Push Button by keeping Auto / Manual switch in manual mode position. Under Run mode valve will operate through Current source of the Panel by keeping Auto / Manual switch in manual mode position. Under Run mode valve will be operated through programmable Input signal from DCS OR QCS in the form of 4-20mA OR 0 to 10 V DC OR Pulse Input by keeping Auto / Manual switch in Auto mode position[Valves Actuator can be site calibrated to understand DCS OR QCS language]
- Provision for fast & slow operation through Toggle selection. Under Run mode [either Auto OR Manual selection] if fast operation is required then operate the toggle switch to fast mode, for slow operation operate the toggle switch to slow mode.



- Under fast mode valve will travel quickly to the nearest Input signal position and final position will be reached slowly through intelligent circuit operation. Under slow mode valve will reach to the required Input signal position slowly & proportionately through intelligent circuit operation.
- Inbuilt Digital Display for Valve position indication in percentage

General arrangement of test bed for **Testing of Valve**

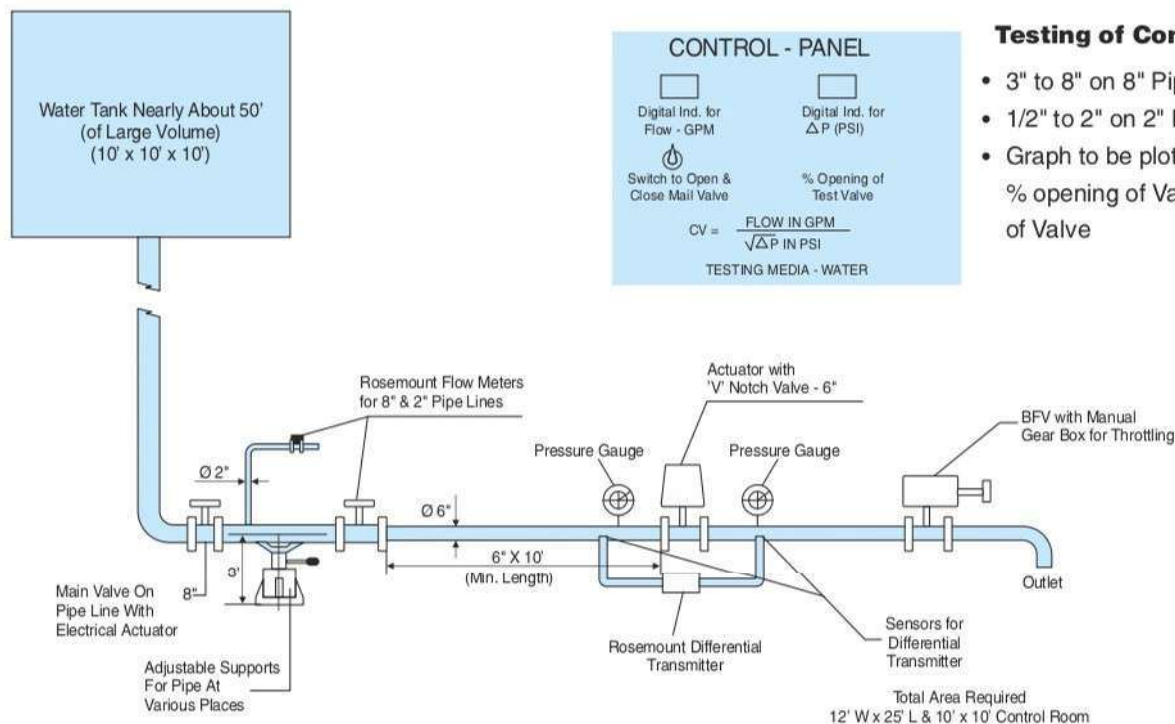

Flow Capacities & Characteristics

Valve Size DN	Cv at Degrees Open								
	10	20	30	40	50	60	70	80	90
25	0.1	0.72	1.8	3.5	5.7	8.6	12.4	17.6	25
40	0.21	1.4	3.7	7.4	12.3	18.9	28	40	57
50	0.5	3.2	7.2	13.2	21	32	47	70	110
75	7	19	34	56	85	124	185	239	280
100	13	33	59	94	140	195	271	361	462
150	19	54	110	176	260	371	519	716	945
200	45	104	185	291	425	589	825	1172	1675
250	92	220	354	572	835	1150	1620	2250	3180
300	120	287	461	746	1090	1500	2120	2940	4150
350	145	292	660	1105	1670	2380	3250	4340	6675
400	200	397	895	1503	2280	3240	4428	5908	9085
500	240	508	1158	2000	3042	4317	5902	7874	12109

'V' Notch Segmented Ball Valve **Shaft Downstream**

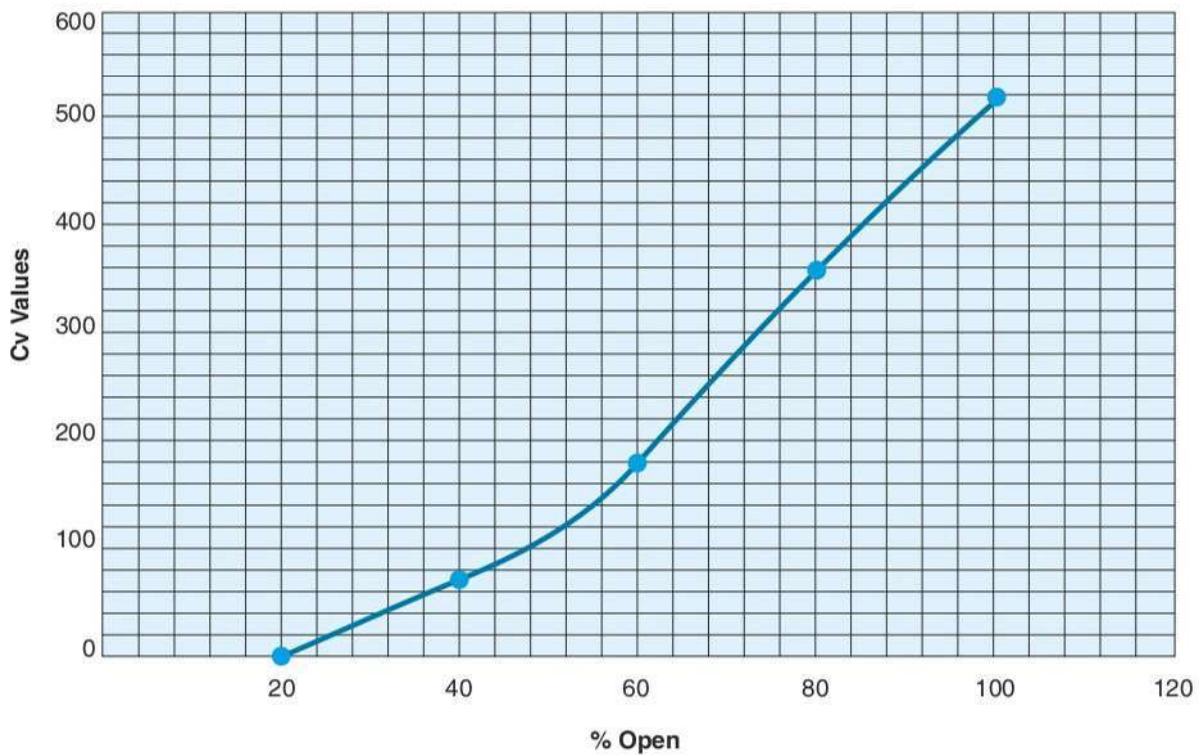

V Notch Ball - 100mm 150#, Shaft Downstream

Part List - 'V' Notch Ball Valve

Seat Ring

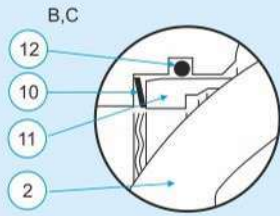

Type -02, -06

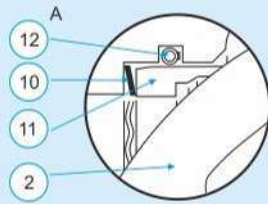

Type -01, -05, -07

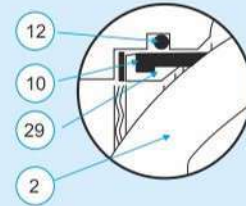

Type -11, -12, -15, -16, -17

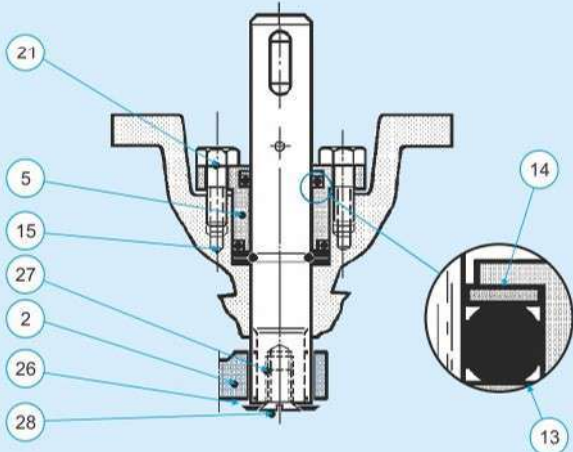

O-ring Sealings : Type -01, -02, -05, -06, -11, -12, -15, -16

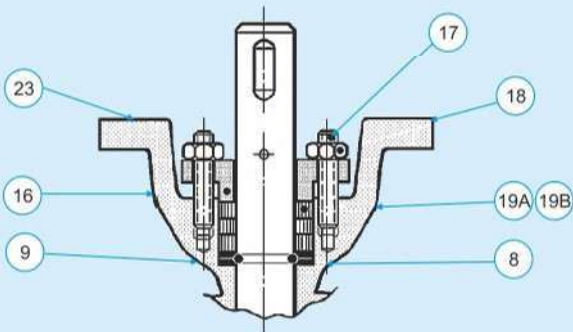
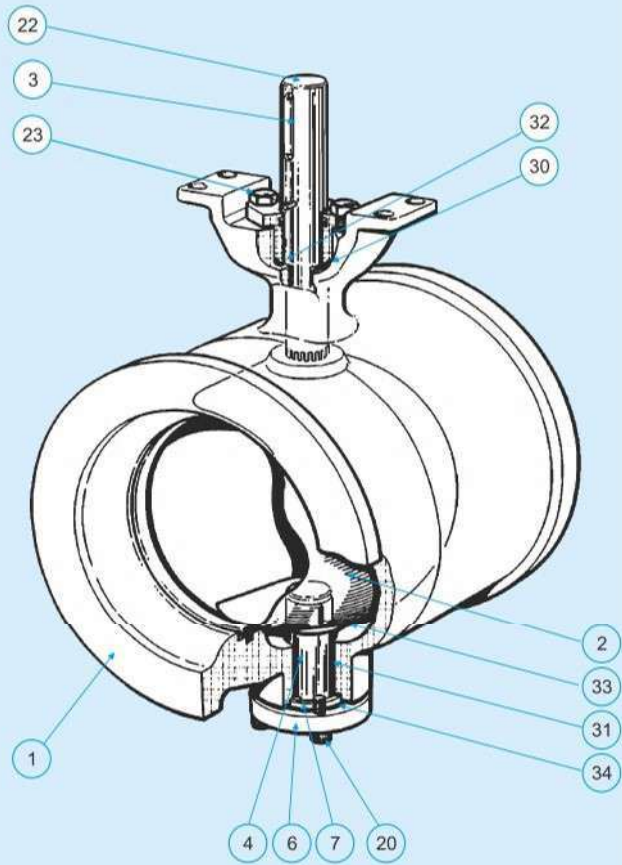

Stuffing box : Type -04, -07, -14, -17

Item	Qty	Part	Material
1	1	Body	EN1.4408/CF8M
2	1	Ball sector	EN1.4408/CF8M hard chrome plated
2	1	Ball sector	EN1.4408/CF8M
3	1	Stem, upper	EN1.4460
4	1	Stem, lower	EN1.4460
5	1	Gland cover	EN1.4408/CF8M
6	1	Bottom cover	EN1.4408/CF8M
7	1	Gasket	Graphite
8	1	Locking segment	EN1.4436
9	1	Bearing seat	EN1.4460
10	1	Compr ring	EN1.4436
11	1	Seat ring	Alloy 6
12A	1	Seat seal	PTFE

Item	Qty	Part	Material
12B	1	Seat seal	EPDM
12C	1	Seat seal	FPM
13A	1	O-ring	EPDM
13B	1	O-ring	FPM
14	1	Backing ring	PTFE
15A	1	O-ring	EPDM
15B	1	O-ring	FPM
16	1	Gland cover	EN1.4408/CF8M
17	2	Bolt	A4
18	2	Nut	A4
19A	1	Boxpacking	Graphite
19B	1	Boxpacking	PTFE
20	4	Bolt	A4
21	2	Bolt	A4

Item	Qty	Part	Material
22	1	Key	Steel
23	1	Indicating pin	SS
26	1	Washer	A4
27	1	Thread insert	Stainless
28	1	Bolt	A4
29	1	Seat ring / Backup ring	PTFE/SS
30	1	Stem bearing	Metaloplast
31	1	Stem bearing	Metaloplast
32	1	Washer	A4
33	1	Cylindrical pin	EN1.4460
34	1	Washer	Metaloplast

Exploded View 'V' Notch Ball Valve

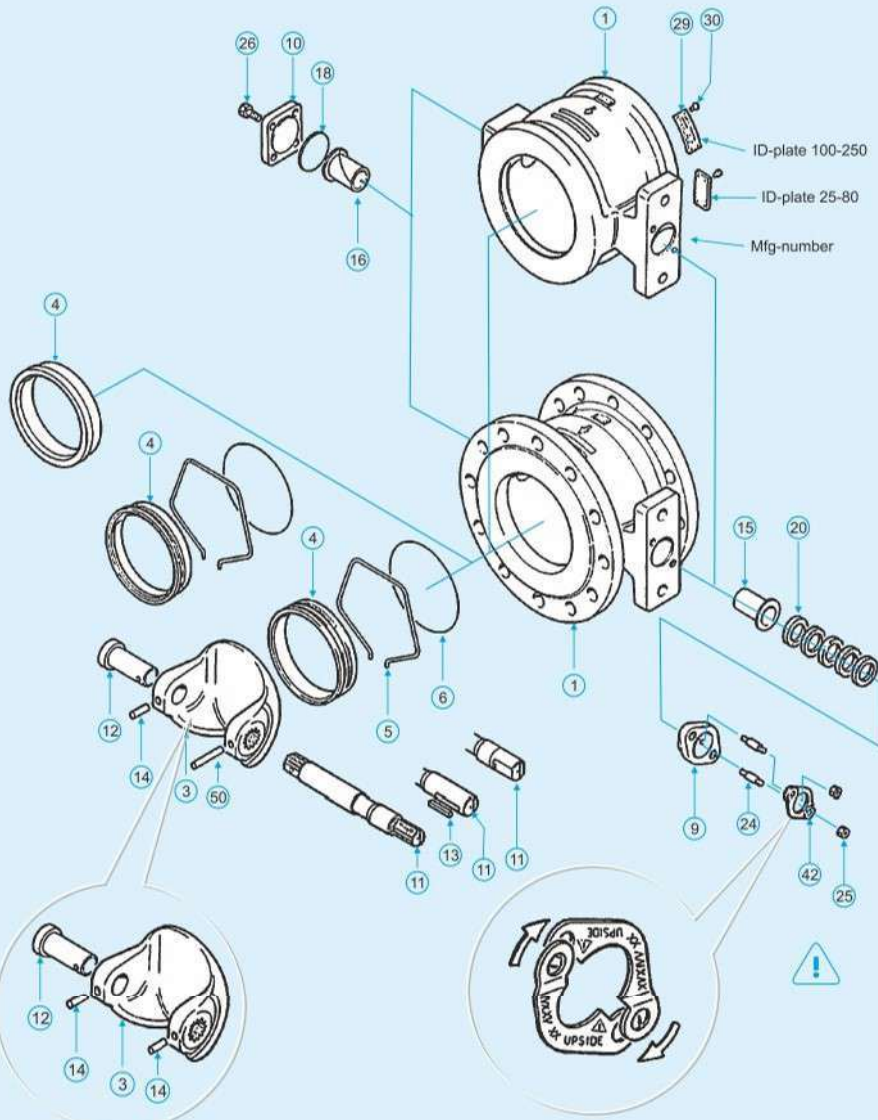

Item	Qty.	Description
1	1	Body
3	1	Segment
4	1	Seat
5	1	Lock spring
6	1	Back seal
9	1	Gland follower
10	1	Blind flange
11	1	Drive shaft
12	1	Shaft
13	1	Key
14	1	Pin
15	1	Bearing
16	1	Bearing
18	1-2	Gasket
20	5	Gland packing
24	2	Stud
25	2	Hexagon nut
26	2-4	Hexagon bolt
29	1	Identification plate
30	2	Screw
42	2	Retainer plate
50	1	Tapered pin

Parts 4, 5 and 6 are supplied as a set.

Pressure - Temperature Ratings

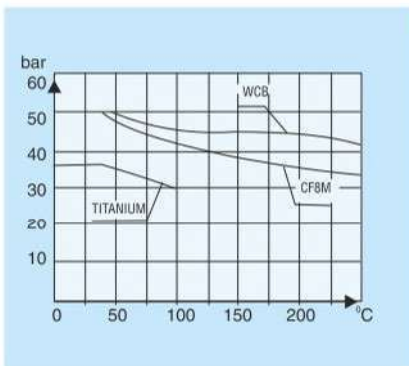

Maximum pressure differentials of

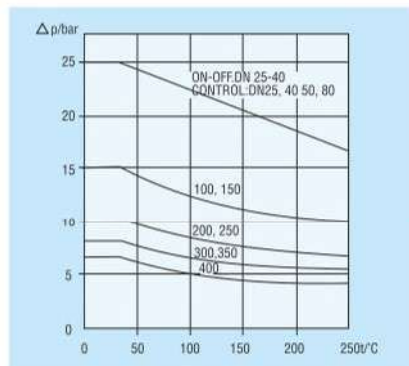

Maximum pressure differentials of acid-resistant

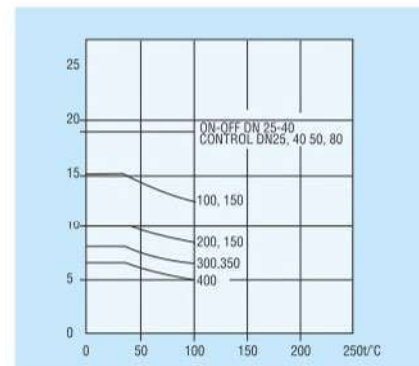

Maximum pressure differentials of titanium

Constructional View of Intelligent Electrical Actuator

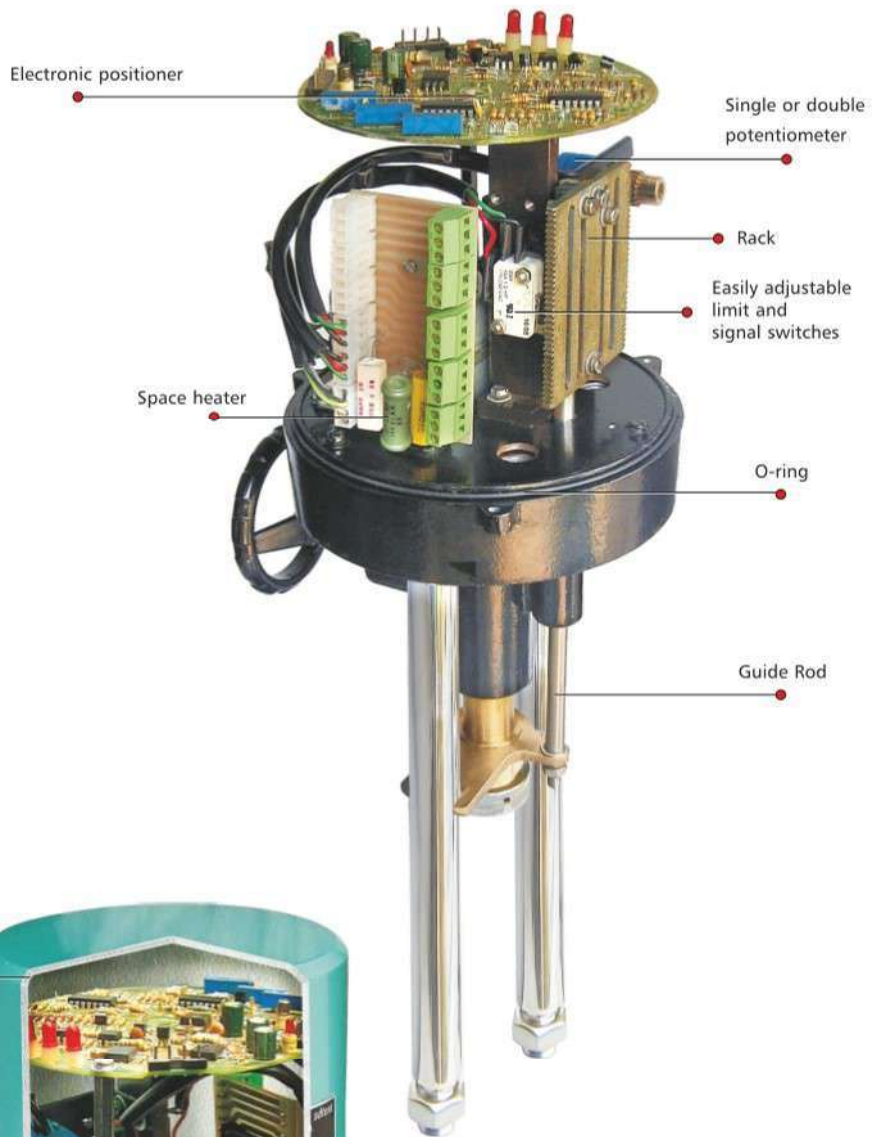

The top cover, made of high-quality graded Aluminum, ensures protection class IP 65/IP67 and allows outdoor installation

Additional stroke switches or intermediate switches

Electronic position transmitter

Synchronous stall duty motors without over-run are used for precise positioning to allow mode of operation 54-1200 cycles/hr

Spur gear with minimum backlash and low wear for precise positioning of the valve stem; high actuator output stiffness due to self-locking drive

The proven disc spring coupling provides a definite setting force and tight closing with self alignment. The rotation lock serves as a mechanical stroke indicator

The mounting support rods made of non-corrosive steel for simple, versatile mounting to the valve



Comfortable hand operation by means of hand wheel with clutching/de-clutching mechanism

Overall Dimensions of 'V' Notch Segmented Ball Valve with Intelligent Electrical Actuator

1550

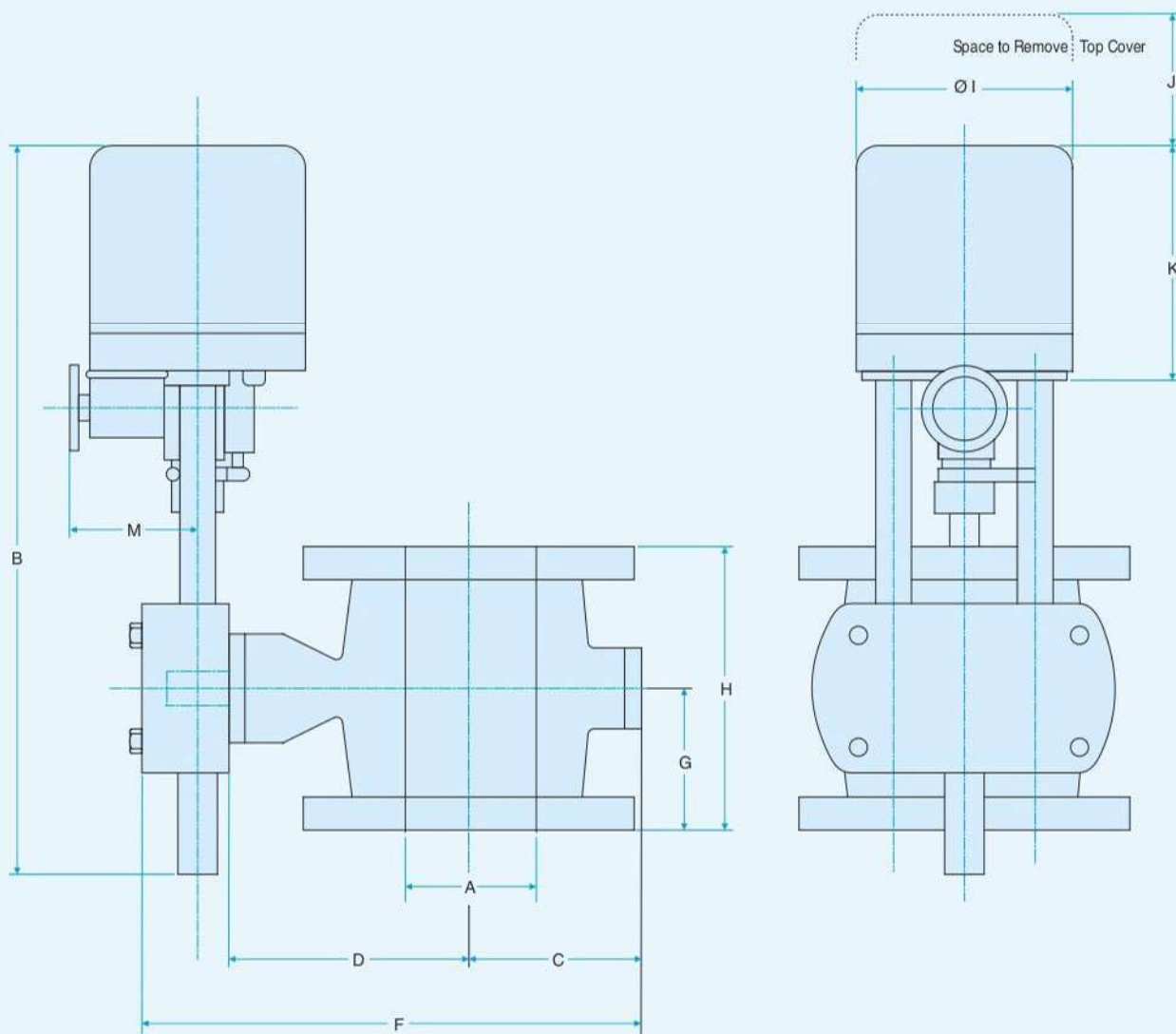

Model Number	DN	A	B	C	D	F	G	H	mass, kg		I	J	K	M	Actuator Type
									wafer	flanged					
1550/40/WAF/CP	40	32	600	75	125	295	57	114	16	---	165	160	200	100	TPLD NO/200-1
1550/50/WAF/CP	50	40	600	90	131	316	62	124	17	---	165	160	200	100	TPLD NO/200-1
1550/65/WAF/CP	65	50	600	101	139	335	68	135	19.5	---	165	160	200	100	TPLD NO/200-1
1550/80/WAF/CP 1550/80/FLG/CP	80	70	600	110	145	350	83	165	22	28	165	160	200	100	TPLD NO/200-1
1550/100/WAF/CP 1550/100/FLG/CP	100	85	600	120	167	382	97	194	26	35.5	165	160	200	100	TPLD NO/200-1
1550/150/WAF/CP 1550/150/FLG/CP	150	130	600	155	195	445	115	229	36	51.5	165	160	200	100	TPLD NO/200-1
1550/200/WAF/CP 1550/200/FLG/CP	200	170	688	195	236	516	130	243	61.5	83.5	210	200	250	133	TPLD NO/600-1
1550/250/FLG/CP	250	208	688	230	295	620	155	297	---	119.5	210	200	250	133	TPLD NO/600-1
1550/300/FLG/CP	300	258	688	260	320	675	183	338	---	164.5	210	200	250	133	TPLD NO/600-1
1550/350/FLG/CP	350	282	688	290	360	745	200	400	---	193.5	210	200	250	133	TPLD NO/600-1
1550/400/FLG/CP	400	316	688	308	383	786	224	400	---	230.5	210	200	250	133	TPLD NO/600-1
1550/500/FLG/CP	500	400	688	371	460	926	288	508	---	367.5	210	200	250	133	TPLD NO/600-1



OUR OTHER PRODUCTS



- Solenoid valves.
- Pneumatically operated control valves.
- Motorised valves.
- Pneumatic & Electric Operated Ball / Butterfly valves.
- Pneumatic & Motorised Dampers.
- Pneumatic & Motorised VIV Dampers.
- Motorised Rising & Non-rising Sluice valve.

- Heavy duty – Single phase & Three phase actuators for operating Gates & Chutes.
- Pneumatic & Motorised pinch valve.
- Pneumatic & Motorised Flush Bottom valve.
- Entire range of Electrical Actuator.
- And Instrumentation Product likes Pressure Transmitter, PID Controller, Flow meter etc., for System Integration.

NOTE : TECHNICAL SPECIFICATIONS, DETAILS & DIMENSIONS ARE SUBJECT TO CHANGE WITHOUT PRIOR NOTICE. DIMENSIONS IN THE TABLE ARE APPROXIMATE SUBJECT TO FINAL CONFIRMATION BY KRISS INSTRUMENTATION



Head Office, Bangalore

KRISS

KRISS INSTRUMENTATION

Registered Office / Works :

Shop No. 1106, 10th Main Road, R.P.C. Layout,

Tel. : +91 80 2330 2145 / 2314 1104 / 2340 2297

Fax : +91 80 2330 5729