

2 Way **Butterfly Valve** Fitted With
Reversible Stayput Type **Electrical Actuator**
In **Single Phase / Three Phase**
Actuator Construction

1250SERIES



YES WE CARE

SIDE

SUDE Offers Proven Design Butterfly Valve With Preferred Features For Advance Technology



ADVANCED TECHNOLOGY

Sude is totally committed to providing highest quality valves and outstanding service to our customers. Complete customer satisfaction is our goal.

Incorporating the latest in valve manufacturing technologies Sude assures a consistent, high quality valve that will provide years of trouble-free service.

A butterfly valve is from a family of valves called quarter turn valves. The "butterfly" is a metal disc mounted on a rod. When the valve is closed, the disc is turned so that it completely blocks off the passageway. When the valve is open, the disc is rotated a quarter turn so that it allows unrestricted passage. The position of the disc is effected from outside the valve.

Butterfly valves are utilized in many aspects of our lives. One of the most common examples of a butterfly valve is in the carburetor of car. In a carbureted car, the "Gas" pedal actually operates a butterfly valve that controls the engine's air intake. When the driver depresses the gas pedal all the way to the floor the butterfly valve opens all the way as described above to allow air to pass freely into the carburetor combustion chambers, where it is ignited by the engine.

A butterfly valve can also be partially opened. When a car is at idle, the valve is open only slightly allowing just enough air to pass

through to maintain the idle speed. When the gas pedal is pressed a little the butterfly valve opens a little further and so on.

There are different kinds of butterfly valves, each adapted for different pressures and different usage. The resilient butterfly valve, which uses the flexibility of rubber, has the lowest pressure rating. The high performance butterfly valve, used in slightly higher-pressure systems features a slight offset in the way the disc is positioned. Which increases the valve's sealing ability and decreases its tendency to wear. The valve best suited for high-pressure systems is the tricentric butterfly valve, which makes use of a metal seat and is therefore able to withstand a greater amount of pressure.

The butterfly valve has head loss characteristics of a full bore valve. The design is based on use of an engineered disc of the same dia as the bore of the pipe arranged to pivot such that when it is across the bore is close off the flow path. When turned through 90 ° the disc provides minimum resistance to the flow.

The butterfly valve has been developed for many duties it now provides optimum solution for a leak tight on-off valve supplanting the gate valve. The butterfly valve can be engineered as a small valve of 25mm bore and can be made for extremely large sizes above 5000mm bore. Depending on the valve size high working pressures can be handled.

The main variations for this valve are the methods of sealing the perimeter of the disc in its closed position. The simplest variation is to use an elastomer lined bore which is an interference fit on the disc. The other variations are based on off setting the disc plane from the axis of rotation allow the disc to close against a circular face seal such that the fluid pressure increases the seal effect. Metallic seals are available allowing the valve to be used for a wide range of fluids at high temperatures.

A PROVEN DESIGN...

With features and benefits engineers and users prefer and manufactured with advanced technology, Sude offers Butterfly Valve for today's water \ wastewater professional a superior valve at an affordable price.

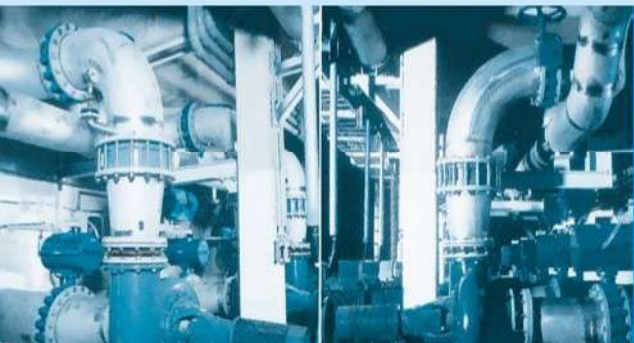

Index

Advance Technology	01
Design Features of Butterfly Valve	04
PN10 Rating Wafer Type Butterfly Valve	05
PN16 Rated Wafer Type Butterfly Valve	06
Flow Rate Characteristic Curve	07
Actuator Construction	08

An outstanding feature of the Butterfly Valve is the unique seat ring design (illustrated) which gives bubble tight closure against flow in either direction at pressures up to 10 Kgf/cm² (150 psi).

This is achieved with an increased thickness of the seat ring at the point of closure whereby the disc perimeter is forced into the ring, the reaction of which completes the seal.

The grooves in the body which accommodate the ears of the seat ring are designed to accept the calculated compression of the ring when bolted between the flanges. This prevents distortion of the seat ring which could affect correct shut-off or increase operating torque.

Butterfly Valves are fitted with seat rings in a variety of rubber materials which all offer high wear resistance and stable elasticity. Higher durability over metallic seats is assured.

A variety of compounds is offered to suit most fluids.

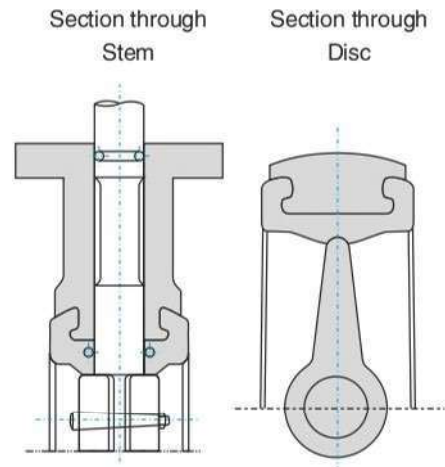

Leakproof Stem Seal

There is no media contact with the body. A completely leakproof stem seal however is offered with Butterfly Valves by the three sealing points illustrated.

- Primary Seal : Close fit between machined flat face of disc and large raised area of seat ring ensures perfect seal.
- Secondary Seal : 'O' ring between stem and body eliminates ingress of dust and dirt.
- Tertiary Seal : 'O' ring between stem and seat ring. A stainless steel 'O' ring housing is moulded in the seat ring to ensure a perfect stem seal.
- Butterfly valves therefore can be used on vacuum service.

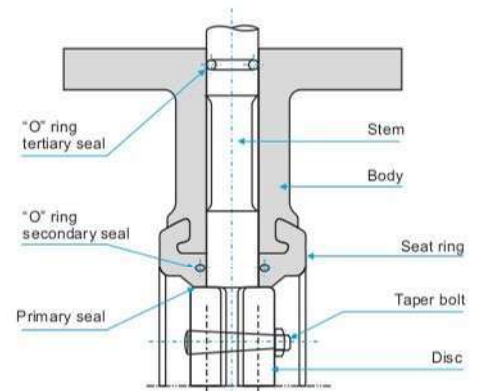

Concentric and Eccentric Disc Comparison

Concentric Disc Design

- Developed for water services up to 10 Kgf/cm² (150 psi.)
- Handles flow in either direction.
- Body fully protected from corrosion by liner.
- Low pressure drop (good Cv characteristics).
- Streamlined concentric disc minimizes turbulence and erosion.
- Self Cleaning seat area.
- May be installed with shaft horizontal or vertical.
- Greater thickness of liner at seating area offers longer service life.
- Flange gaskets not required.

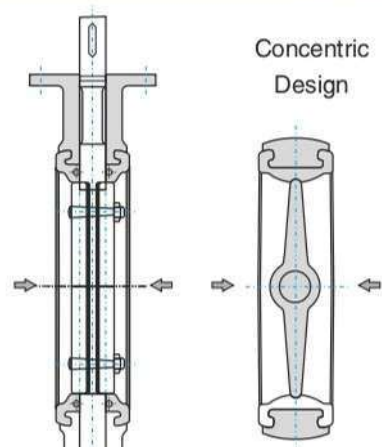

Eccentric Disc Design

- Developed for oil cargo services up to 16 Kgf/cm² (240 psi).
- Accepts flow in one direction only.
- Not usually fully lined.
- Higher pressure drop especially in sizes under 150 mm.
- Eccentric Disc generates more turbulence and erosion.
- Seating areas not self cleaning.
- Should be installed with shaft horizontal.
- Smaller higher stressed seating area prone to give shorter service life.
- Flange gaskets required. No control over bolt pressure on gaskets.

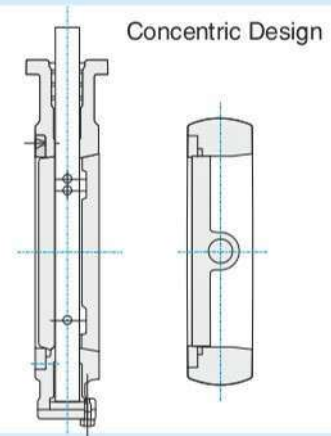

Reduced Flow Resistance

The concentric streamlined design of body and disc offers minimal resistance to flow. By installing Butterfly valves instead of globe valves the pressure drop through a pipe system can be greatly reduced.

When partly opened, gate valves "Chatter" and tend to self destruction.

This cannot occur with Butterfly Valves which give smooth flow characteristics. The rugged construction of the disc and the additional bearing points along the stem, helps to combat spindle deflection under pressure surge and the stainless steel taper bolts ensure positive disc attachment.

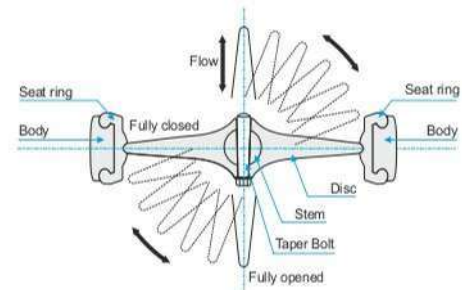

Preferred Features

Sude offers Butterfly valve which is designed to provide long life and trouble-free performance. If repairs do become necessary, the valve is also designed for easy field repair. The shaft seal incorporated V-type packing which is easily replaced in the field without removal from the line. Adjustment of the resilient seat is easily performed with a socket wrench...no two-part epoxy or urethane to mix...no hypodermic needles to special order. Our unique Tri-Loc seat retention system assures seat retention by retaining the seat through three different mechanical means to assure long-term dependable service.

Comparison with Conventional Valves

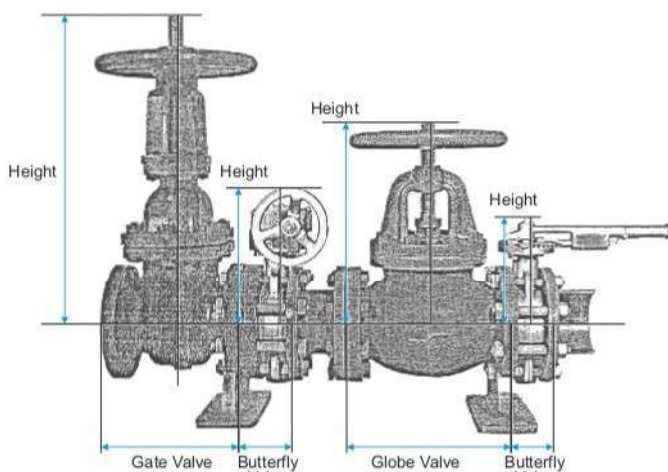

1. **Light and Compact** : Butterfly Valves offer savings in weight, length and headroom. Design is more compact and costs are reduced.
2. **Easy Maintenance** : The simple design of Butterfly Valves facilitates quick dismantling and parts replacement. maintenance cost savings are considerable.
3. **Smooth & Quick Operation** : 90° turn for Open/Shut operation. Leaver action simple one man function. Gear operation is three to five times faster than standard gate valves.
4. **Low Cost** : substantially cheaper than

Mating pipe flanges should be apart to allow free access for valve. Disc should be slightly off its seat.

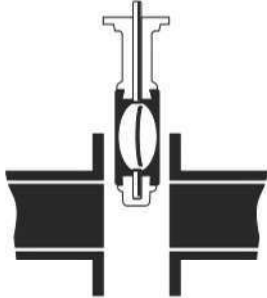

Disc shall be in slightly open position so that when flange bolts are inserted will ensure that seat distortion does not take place.

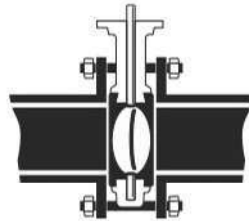

Valve is to be centralised. Disc to be kept fully open and ensure that disc does not foul with the internal diameter or the pipe. Evenly tighten the flange bolts, and the valve is secured.

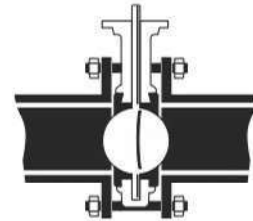

Design Features

Stem connection available in standard sizes or optional sizes to match standard secondary top plate drilling.

Top plate double drilled to fit ISO 5211 dimensions and standard secondary bolt circle dimensions. All handles, gear operators and pneumatic actuators are designed to mount directly to Valves.

Nylon PA 12 coated disc option ensures excellent corrosion resistance to several chemical media. The hard, non-porous sintered polymer has very low hygroscopicity and is suitable for use in drinking water and non-alcoholic foodstuffs.

One piece stem with close tolerance double D drive eliminates the need for disc screws or taper pins.

Double O-rings are molded in both upper and lower journals providing a superior secondary seal.

Unique "Center-Lock" seat design virtually eliminates any seat movement during the seating and un-seating of the disc.

Heavy duty square-grooved seat design with molded O-ring seals to serve as flange gaskets. EPDM and Buna-N seats are peroxide cured to yield the best elastic

Unique stem retention system to provide blow-out proof stem and easy assembly and dis-assembly of valve.

Heavy duty acetal bushing absorbs the forces acting on the stem/disc assembly due to line pressure.

Bi-directional 'IT cup stem seal.

Heavy duty one-piece body with extended neck for 2" piping insulation. Standard coating is two coats of hard, Zinc-rich epoxy for excellent corrosion resistance.

Two flange locating holes for sizes up to 12" and four flange locating holes from size 14" to 24" for easy alignment of valve during installation. They meet ANSI #125 /150 or other world drilling standards.

High strength disc with hand polished disc edge and hubs.

Precision machined radius on the upper and lower disc hubs is pressed against upper and lower seat sealing faces for achieving primary sealing between disc and seat.



PN10 rated has integrally molded elastomer body liner, is designed to outperform valves with loose liners. The elastomer liner is molded directly in the body & vulcanized in-situ, ensures that the liner lasts the entire life of the valve. These valves are mostly used for HVAC systems and are available for a size ranging from 50mm to 300 mm used for Water & Air Services.

The integrally molded liner provides a stable seat which overcomes the tendency of the disc to push the seat out of position. In situ vulcanizing provides the desired strength to the liner. Plasticizer in the elastomer formulation ensures a smooth surface which minimizes the friction between disc and liner due to which though the sealing is tight the operating torque is low.

Butterfly valve has a contoured disc which ensures a smooth flow with minimum resistance and of course with a improved flow coefficient (Cv) and they are with flangeless connection mainly suitable for holding between the flange Confirming to 150 rating

Valve Features And Benefits

1. One Piece Ductile Iron Body Casting Ensures High Strength with Minimum Weight. Compatible with ANSI 125/150
2. Top Actuator Mounting Pad to ISO-5211 Direct Mount Capabilities.
3. O-Ring Give Positive Sealing in Both Directions
4. PTFE Bushings for Shaft Support and Positive Alignment
5. One Piece Shaft Ensures Positive Disc Positioning
6. Precision Machined Disc Ensures Tight Shut-off with Minimum Torque and Longer Seat Life.
7. Phenolic Backed Cartridge Seat is Stretch Resistant, Non- Collapsible and Blowout Proof
8. Seat Face Negates Need for Gaskets

Material Specifications for PN10 Rating Valve

The concentric streamlined design of body and disc offers minimal resistance to flow. By installing Butterfly valves instead of globe valves the pressure drop through a pipe system can be greatly reduced. When partly opened, gate valves "Chatter" and tend to self destruction. This cannot occur with Butterfly Valves which give smooth flow characteristics. The rugged construction of the disc and the additional bearing points along the stem, helps to combat spindle deflection under pressure surge and the stainless steel taper bolts ensure positive disc attachment.

- **Sizes** : Ranging from 50 mm to 300 mm
 - **Body Material** : Cast Iron to BS 145Gr. 200
 - **Body Liner** : Nitrile Rubber OR EPDM
 - **Disc Material** : Cast Iron to BS 1452Gr 250
 - **Shaft Material** : BS970-080M40
 - **Characteristic** : On, Off / Linear Control
Up to 60 degree opening
- } Other options
on request

Pressure - Temperature

Liner Material	Temperature (max)	Working Pressure (bar)	Test Pressure (bar)	
			Body	Seal
Nitrile	70°C	10	15	11
EPDM	90°C			

Slim Seal Wafer Type Butterfly have an integrally molded in-situ bonded elastomer liner available in a size range of 50 to 600 mm with a pressure rating of PN16.

STANDARDS:

2" to 12" valves confirm to the requirements of BS5155 & 14" to 24" valves confirm to API 609 and ISO 5752. The valves are of short pattern type and have been designed to fit without gaskets between flanges drilled to BS 10 Table 'D', 'E' & 'F', ANSI 125 / 150, DIN ND 10 / 16, BS 4504 (PN10/16), Table 6 to 9 of IS6418, Tables 10 to 20 of IS6392 and Tables 4 to 6 of IS 1538.

Features & Benefits

FEATURES	BENEFITS
Intrgrally moulded in - situ bonded body seat	Lower Torque requirement No maintenance No tearing and distortion of liner Exceptionally long seat life Uniform sealing
PTFE coated S.S Shaft	Permanent dry lubrication Ease of operation Prevents corrosion on shaft
Primary and secondary seals integral with body lining	Ensures compatibility with line fluid
Different disc and seat combination available	Wide application Range
Weatherseal feature (50 to 300 mm sizes)	Atmospheric sealing to valve internals
Spherical machined and polished disc	Ensures longer seat life, easier operation and tight shut off
External coating of Rust preventive primer and final coat of enamel paint	Provides excellent external corrosion resistance

Material Specifications PN16 Rating Valve

Part	Material of Construction	
Body	Cast Iron to BS 1452 Gr 220 SG Iron to BS 2789 Gr 420/12 SS to ASTM A 351 Gr CF8/CF8 m CS to ASTM A 216 Gr WCB	Other options on request
Body Liner	Black Nitrile EPDM (General purpose)	
Disc	SG Iron to 2789 Gr 420/12 nylon coating Al. Bronze to BS 1400 Gr. AB2/AB1 SS to ASTM A 351 Gr. CF8/CF8 m edge polished	
Shaft	AISI 410 PTFE coated for permanent dry lubrication	
Bearings	PTFF Sheet bearings provided for valves with SS discs. Sizes 350 to 600 mm have Phosphor Bronze bearings as standard	

ASSEMBLED WITH :

a) Single Phase 230 V AC Actuator Alternatively 24 V AC & 110 V AC OR

Material & Applications

General Applications	Continuous working Temperature Range	Maximum Working Pressure	Disc Material	Seat Material
Oils, Fuels, Water, Air, Gases, Powders, Pellets, Slurries etc.,	Hydrocarbons (Except Aromatics) -10° C to 90° C Other Liquids -10° C to 80° C Dry Services -10° C to 60° C	16 bar	Nylon Coated SG Iron	Black Nitrile (2)
Brines, Sea water, Estuary water, Marine Bilge & Ballast Systems	Liquids -10° C to 80° C	16 bar	Aluminum Bronze	
Steam, Water, Hot Gases, Powders, Slurries and aqueous slurries of an abrasive nature	Liquids -10° C to 120° C Dry Services -10° C to 100° C	14 bar	Stainless Steel Periphery Polished	General Purpose EPDM

Flow Rate Characteristic Curve

The curve shows the relationship between valve opening and rate of flow at a constant pressure differential. Generally Butterfly Valves are most suitable for controlling flow but are not recommended for flow control where the valve opening is below 30°. (Ideal : 35° to 70°)

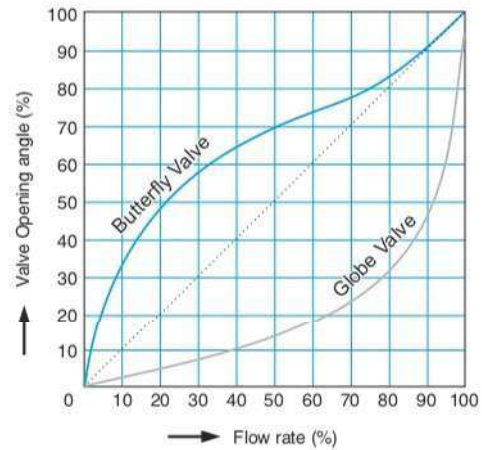

Industrial Applications





Single Phase

Single Phase SDTORK Actuator is provided with Stall duty Motor used for quarter turn application. Actuators are suitable for inching operation too and they can be supplied with extra Limit switches for remote position indication. The Actuators are available in General Purpose, Dust Proof & Flame Proof & Explosion Proof Housing.

Three Phase

SDTORK Actuator is basically a worm gear type reduction gear box. A single stage grease bath worm gear gives quietness and reliability in operation. The valve can be fully opened, fully closed or adjusted to any intermediate position. The rectory force on the worm shaft which is a 'Floating one' is directly proportional to the output torque and is absorbed by a set of disc springs. The lateral movement of the worm shaft under load, trip closes the torque switch. The driving motor is a TEFC /TESC squirrel cage class Induction motor combining low inertia with a high starting and stalling torque. The output sleeve is provided with suitable coupling arrangement and fixing holes as per DIN 3210 for wall mounting. Actuators with IP55 / IP65 / IP67 & IP68 class of protection are available on demand.

Three phase Actuators are fitted with Torque Limit switches & Travel Limit switches & also in built with Manual Hand wheel used for operating the Actuator in case of power failure. Actuator is supplied with various shaft designs to suit ISO mounting.



All actuators can be supplied with various kind of accessories to make system QCS/DCS/PLC/SCADA compatible.

- a) Travel Limit Switches - 2 nos
- b) Auxiliary Limit Switches - 2 nos
- c) Hand wheel for Manual operation
- d) Local position indicator
- e) Potentiometer for feed back
- f) Torque limit switches

The Actuators can be supplied with a panel having Auto Calibration facility.

Actuator can also be supplied with :

Single Phase OR Three phase Panel for switching the valve On / Off through Push Buttons for local operation under manual mode OR through PLC under Auto mode. through 4-20 mA, 0 to 10 V DC or up / down pulses. All this can also be supplied in integral mode.

Common Accessory for Single Phase / Three Phase Actuator :

- a) Honeywell / any other make PID Controller along with PT 100 sensor with built in panel as an option.
- b) Honeywell / any other make pressure Transmitter where based on setting pressure valve will open & close through PID with built in panel as a option.
- c) Sequential timer 0 to 30 channel for sequence operation.
- d) Cyclic timer having On time - 1 to 60 seconds & Off time - 1 to 60 min for sequencing operation. (Other options available on demand)
- e) Stimulator - Panel mounting type having two knobs used for generating 4-20 m A OR Zero to 10 V DC current (against a supply voltage of 230 V AC) for operating the main valve Proportionately.

Control Panel Specification :

- a) Input : Single Phase 230 V AC OR 3 Phase 415 V AC, 4 wire supply.
- b) Output supply: Single Phase 230 V AC OR 3 phase 415 V AC Reversible supply.
- c) Auto / Manual selection : Selector switch provided. In Auto mode open & close operation is controlled by 4-20mA Input & under Manual mode operation is through Push buttons.
- d) Indications : Zero to a100% valve position display, R, Y, B Phase Indication [applicable only for 3 phase] Open & Close, Fully open & Fully close indication.
- e) Main switch - Single Phase OR 3 Phase MCB for mains On / Off.
- f) Phase fail / error protection provided.
- g) Fuse protection provided for each phase.
- h) Protection from over torque - If Actuator gets over torque the torque switch trips & the system protects the motor. Also provided with 10 metres cable for Motor & Feed back with connectors.



Wall mounted control panel.



Integral Starter

Technical Specification of Actuator

SPECIFICATION	DETAILS
Supply Voltage	Single phase 230 V +/-10%, 50 Hz +/-5%, also available in 24 V AC / 110 V AC Supply. Three phase 415 V +/-10%, 50 Hz +/-5%, also available in 380 V AC Supply.
Duty	S2-10 min, S4-30% - 1200 cycles/hour.
Insulation resistance	at least 20 MW under dry condition. at least 2 MW after a damp test.
Actuator life	at least 1x10 ⁶ operations with a running time of 0.75 s at the rated torque.
Self-locking	Self-locking facility of the actuators is provided by mechanical locking feature of worm & worm wheel mechanism. For High Speed Non-Self Locking Actuator used relays or contractors in electric control system to shut off signal.
Local position Indicator	A continuous local mechanical position indicator is provided with actuator which always gives a faithful indication of actuator position independent of power supply.
Adjustable mechanical stoppers	Two adjustable mechanical stoppers are provided with actuator in open & close direction. This feature gives backup safety to final control device.
Auxiliary limit switches	Maximum four numbers of micro limit switches for end position can be provided. Type: 1NO + 1NC change over contact, (2NO + 2NC also available on demand) Contact rating: 10A, 125 - 250 V AC.
Intermediate limit switches	Maximum two numbers of micro limit switches for intermediate end position can be provided. Type: 1NO + 1NC change over contact, (2NO + 2NC also available on demand) Contact rating: 10A, 125 - 250 V AC.
Torque limit switches	Maximum two numbers of micro limit switches for end positions can be provide. Type 1NO + 1NC change over type, (2NO + 2NC also available on demand) Contact rating: 10A, 125- 250 V AC.
Feed back Potentiometer	A multi turn pot meter is used for 0-500 ohms out put feedback value
Position controller	Field/Panel mounted having Input signal: 4-20mA / 0-10 V DC
Position Transmitter	Actuator mounted having Input from actuator mounted Potentiometer & output will be 4-20mA proportionate.
Remote position indicator	Panel mounted digital position indicator for 0-100% open indication.
Space heater	To prevent water condensation, the actuator are fitted with an anti condensation heater called as space heater, the latter can be connected to the AC or DC voltage of 230 V.
Manual Operation	A manual Hand wheel provided for manual Operation in case of Power Failure.
Hammer Blow Effect	A Short time break-away torque is inherent feature of actuator.

Special accessories also can be supplied on request after confirmation with SUDE

2-way Butterfly Valve – PN10 Rating With Single Phase Electrical Actuator

1250

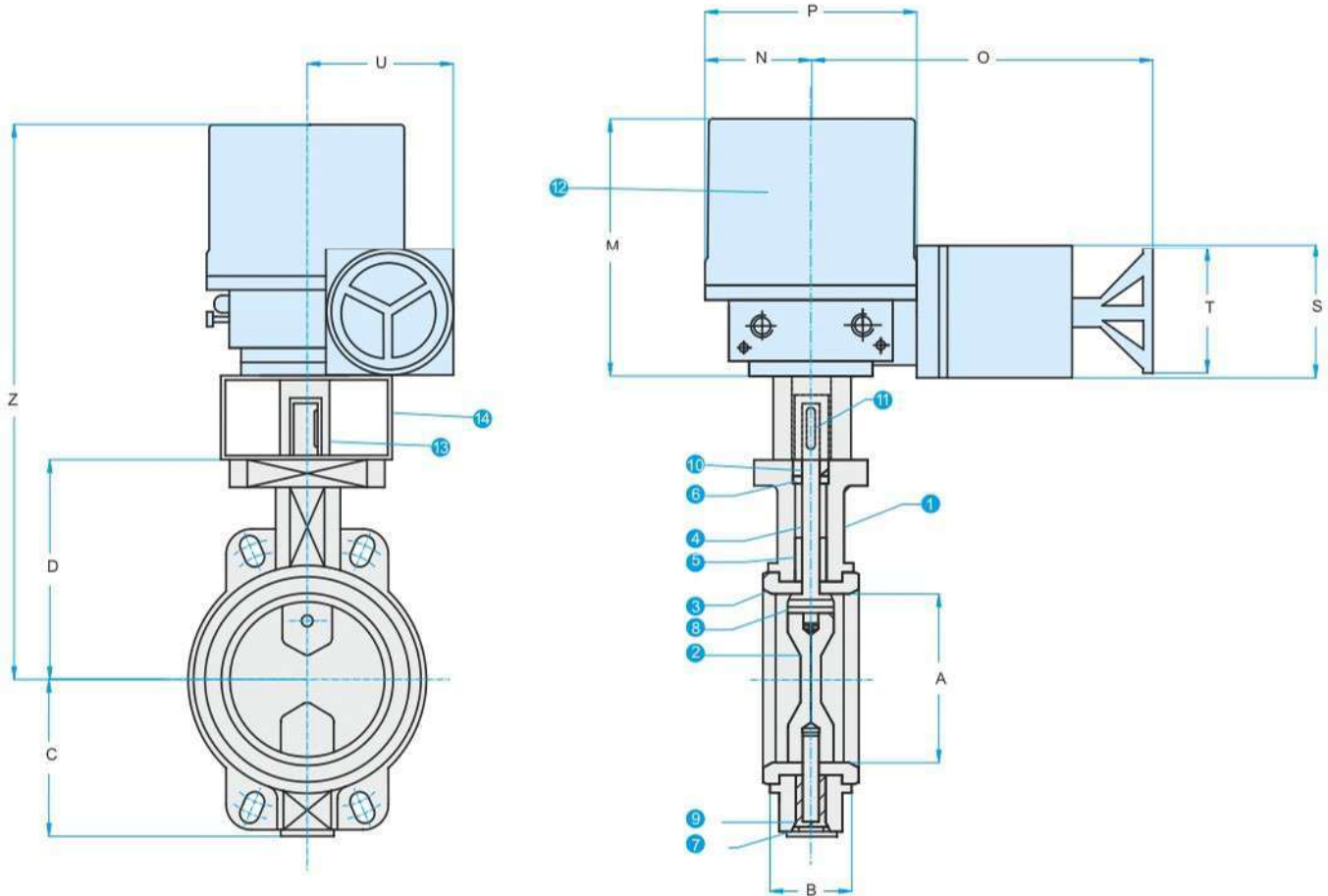

SL NO.	PART	MATERIAL
1	BODY	CAST IRON
2	DISC	SG IRON/SS304/316
3	BONDED SEAT	SLIM SEAL, NITRILE
4	SHAFT	SS410
5	BEARING	STEEL + PTFE
6	O-RING SHAFT	NITRILE
7	O-RING PLUG	NITRILE
8	TAPPER PIN	AISI316
9	PLUG	C-15
10	TOP BUSHING	POLYACETAL
11	KEY	EN8
12	ELECTRICAL ACTUATOR (SDTORK) MAKE	FOR DETAIL REFER MANUFACTURE
13	COUPLER	EN8
14	MOUNTING BRACKET	IS 2062



VALVE SIZE	MODEL NUMBER	A	B	C	D	M	N	O	P	Z	S	T	U	V	WT. OF ASSY IN KGS.	Cv @		OPERATING TIME IN SEC
																60°	90°	
50	1250/PN10/50/SD03	50	43	73	113	175	68	215	138	369	110	100	117	10	14	65	130	17
65	1250/PN10/65/SD03	65	46	80	121	175	68	215	138	393	110	100	117	10	14.5	120	240	17
80	1250/PN10/80/SD03	80	46	88	128	175	68	215	138	406	110	100	117	10	15.5	160	320	17
100	1250/PN10/100/SD03	100	52	104	146	175	68	215	138	445	110	100	117	10	17.5	280	560	17
125	1250/PN10/125/SD05	125	56	116	158	175	68	225	138	488	110	100	117	10	20	430	860	17
150	1250/PN10/150/SD10	150	56	138	174	250	95	270	195	601	110	100	148	6	26	640	1280	20
200	1250/PN10/200/SD20	200	60	163	198	250	95	285	195	725	110	100	148	6	31.5	1200	2400	20
250	1250/PN10/250/SD20	250	68	203	245	250	95	285	195	815	110	100	148	6	41.5	1850	3700	20
300	1250/PN10/300/SD20	300	78	228	270	261	123	355	250	910	110	100	180	3	50.5	2700	5400	20

2-way Butterfly Valve – PN10 Rating With Three Phase Electrical Actuator

SIDE

1250

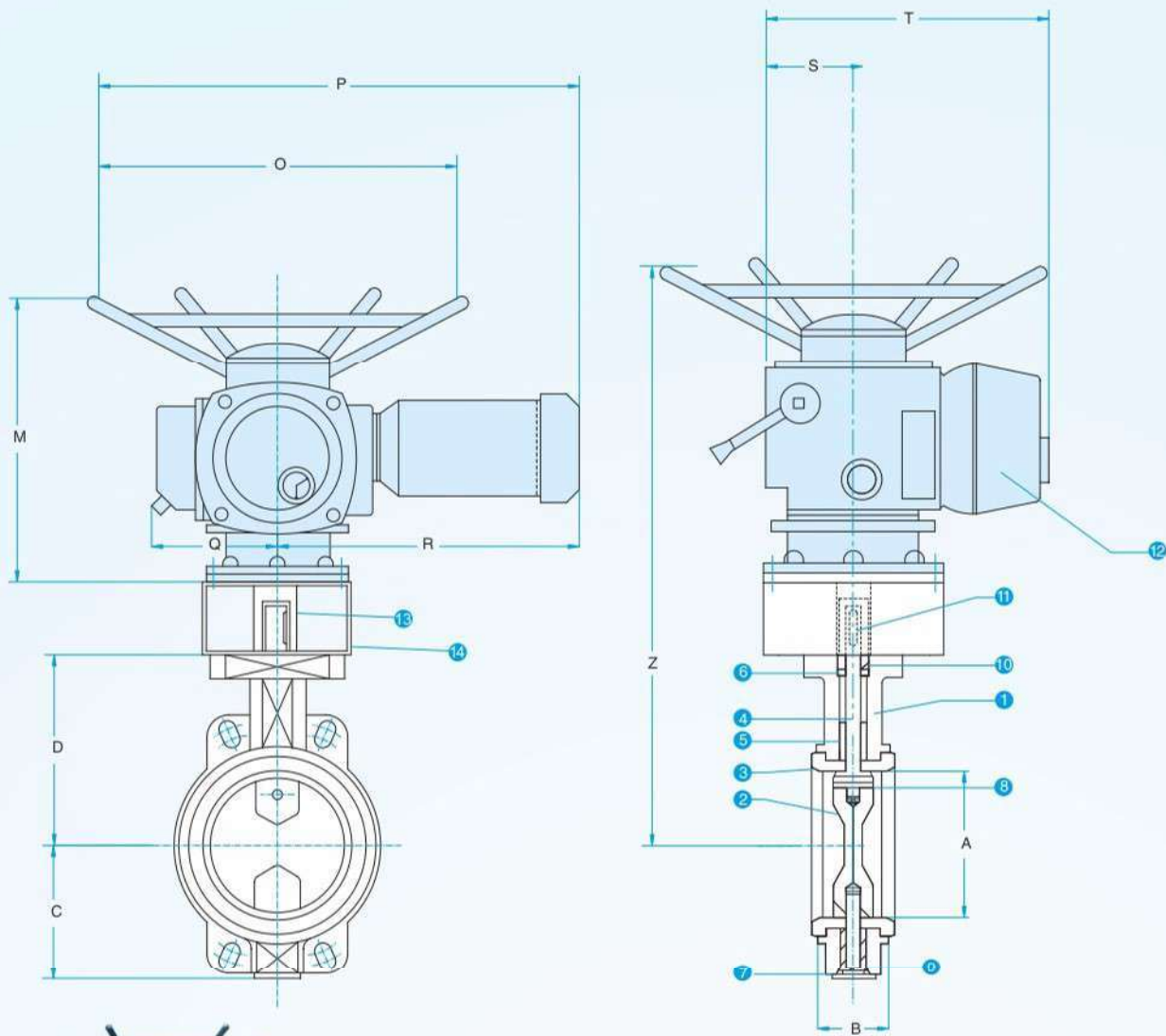

SL NO.	PART	MATERIAL
1	BODY	CAST IRON
2	DISC	SG IRON/SS304/316
3	BONDED SEAT	SLIM SEAL, NITRILE
4	SHAFT	SS410
5	BEARING	STEEL + PTFE
6	O-RING SHAFT	NITRILE
7	O-RING PLUG	NITRILE
8	TAPPER PIN	AISI316
9	PLUG	C-15
10	TOP BUSHING	POLYACETAL
11	KEY	EN8
12	ELECTRICAL ACTUATOR (SDTORK) MAKE	FOR DETAIL REFER MANUFACTURE
13	COUPLER	EN8
14	MOUNTING BRACKET	IS 2062

VALVE SIZE	MODEL NUMBER	A	B	C	D	Z	M	O	P	Q	R	S	T	WT. OF ASSY IN KGS.	Cv @		OPERATING TIME IN SEC
															60°	90°	
50	1250/PN10/50/SD-4000-20	50	43	73	113	554	340	485	685	225	440	85	400	64	65	130	3.5 TO 24
65	1250/PN10/65/SD-4000-20	65	46	80	121	578	340	485	685	225	440	85	400	64.5	120	240	3.5 TO 24
80	1250/PN10/80/SD-4000-20	80	46	88	128	591	340	485	685	225	440	85	400	65.5	160	320	3.5 TO 24
100	1250/PN10/100/SD-4000-20	100	52	104	146	629	340	485	685	225	440	85	400	67.5	280	560	3.5 TO 24
125	1250/PN10/125/SD-4000-20	125	56	116	158	672	340	485	685	225	440	85	400	80	430	860	3.5 TO 24
150	1250/PN10/150/SD-4000-20	150	56	138	174	711	340	485	685	225	440	85	400	86	640	1280	3.5 TO 24
200	1250/PN10/200/SD-4000-20	200	60	163	198	831	340	485	685	225	440	85	400	91	1200	2400	3.5 TO 24
250	1250/PN10/250/SD-4000-20	250	68	203	245	900	340	485	685	225	440	85	400	95	1850	3700	3.5 TO 24
300	1250/PN10/300/SD-4000-20	300	78	228	270	960	340	485	685	225	440	85	400	110	2700	5400	3.5 TO 24

2-way Butterfly Valve – PN16 Rating With

Single Phase Electrical Actuator **SUDE**

1250

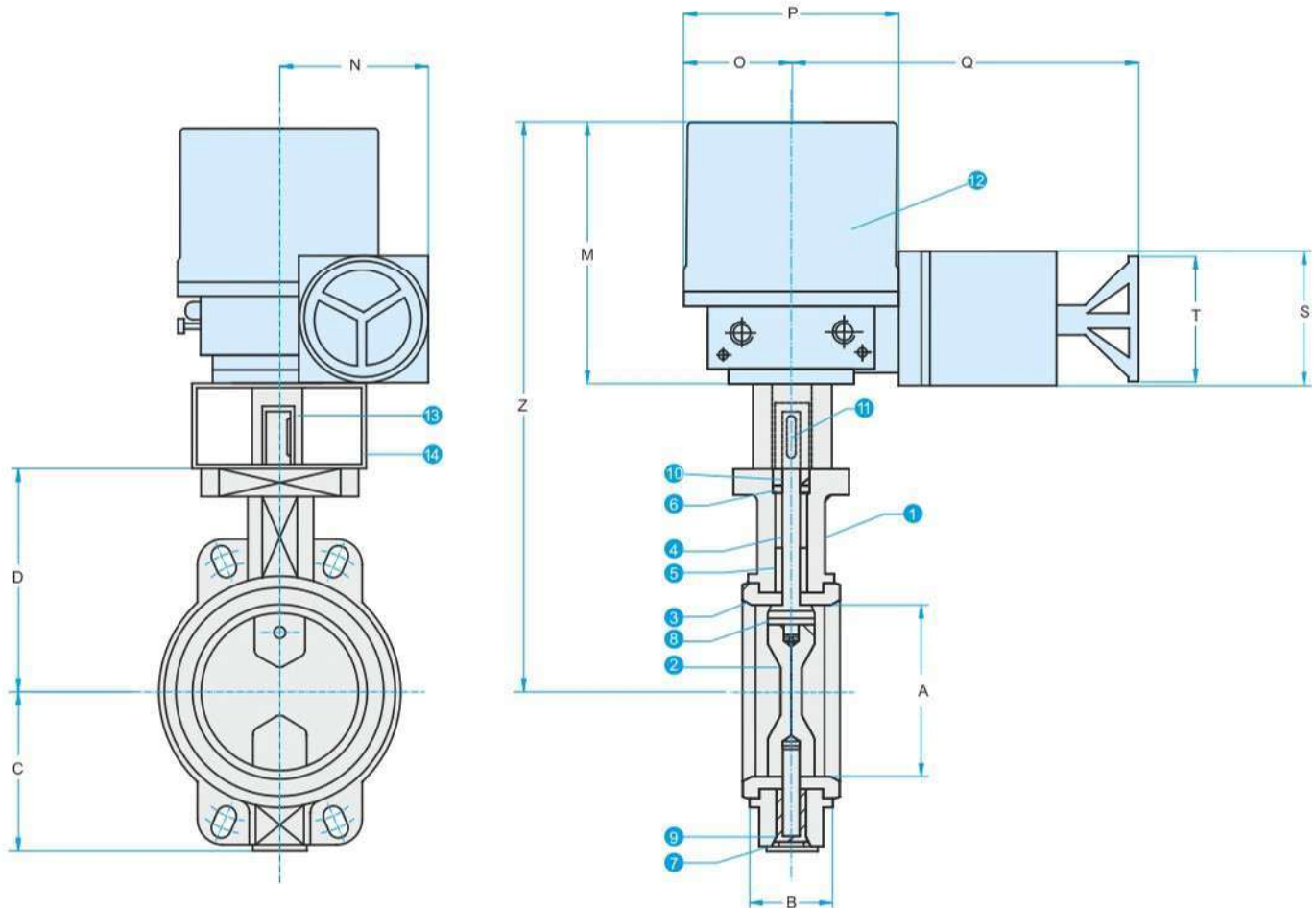

SL NO.	PART	MATERIAL
1	BODY	CAST IRON
2	DISC	SG IRON/SS304/316
3	BONDED SEAT	SLIM SEAL, NITRILE
4	SHAFT	SS410
5	BEARING	STEEL + PTFE
6	O-RING SHAFT	NITRILE
7	O-RING PLUG	NITRILE
8	TAPPER PIN	AISI316
9	PLUG	C-15
10	TOP BUSHING	POLYACETAL
11	KEY	EN8
12	ELECTRICAL ACTUATOR (SDTORK) MAKE	FOR DETAIL REFER MANUFACTURE
13	COUPLER	EN8
14	MOUNTING BRACKET	IS2062



VALVE SIZE	MODEL NUMBER	A	B	C	D	M	O	P	S	T	N	Q	Z	WT. OF ASSY IN KGS.	Cv @		OPERATING TIME IN SEC
															60°	90°	
50	1250/PN16/50/SD03	50	43	73	113	175	68	138	110	100	117	215	424	23.2	65	130	17
65	1250/PN16/65/SD03	65	46	80	121	175	68	138	110	100	117	215	450	23.5	120	240	17
80	1250/PN16/80/SD05	80	46	88	128	175	68	138	110	100	117	225	464	28	160	320	17
100	1250/PN16/100/SD05	100	52	104	146	175	68	138	110	100	117	225	516	33.45	280	560	17
125	1250/PN16/125/SD10	125	56	116	158	250	95	195	110	100	148	270	620	41.4	430	860	20
150	1250/PN16/150/SD20	150	56	138	174	250	95	195	110	100	148	285	655	52.3	640	1280	20
200	1250/PN16/200/SD20	200	60	163	198	250	95	195	110	100	148	285	745	64.8	1200	2400	20
250	1250/PN16/250/SD40	250	68	203	245	261	123	246	110	100	182	340	855	111.7	1850	3700	26
300	1250/PN16/300/SD40	300	73	228	270	261	123	246	110	100	182	340	920	121.5	2700	5400	26

2-way Butterfly Valve – PN16 Rating With Three Phase Electrical Actuator

1250

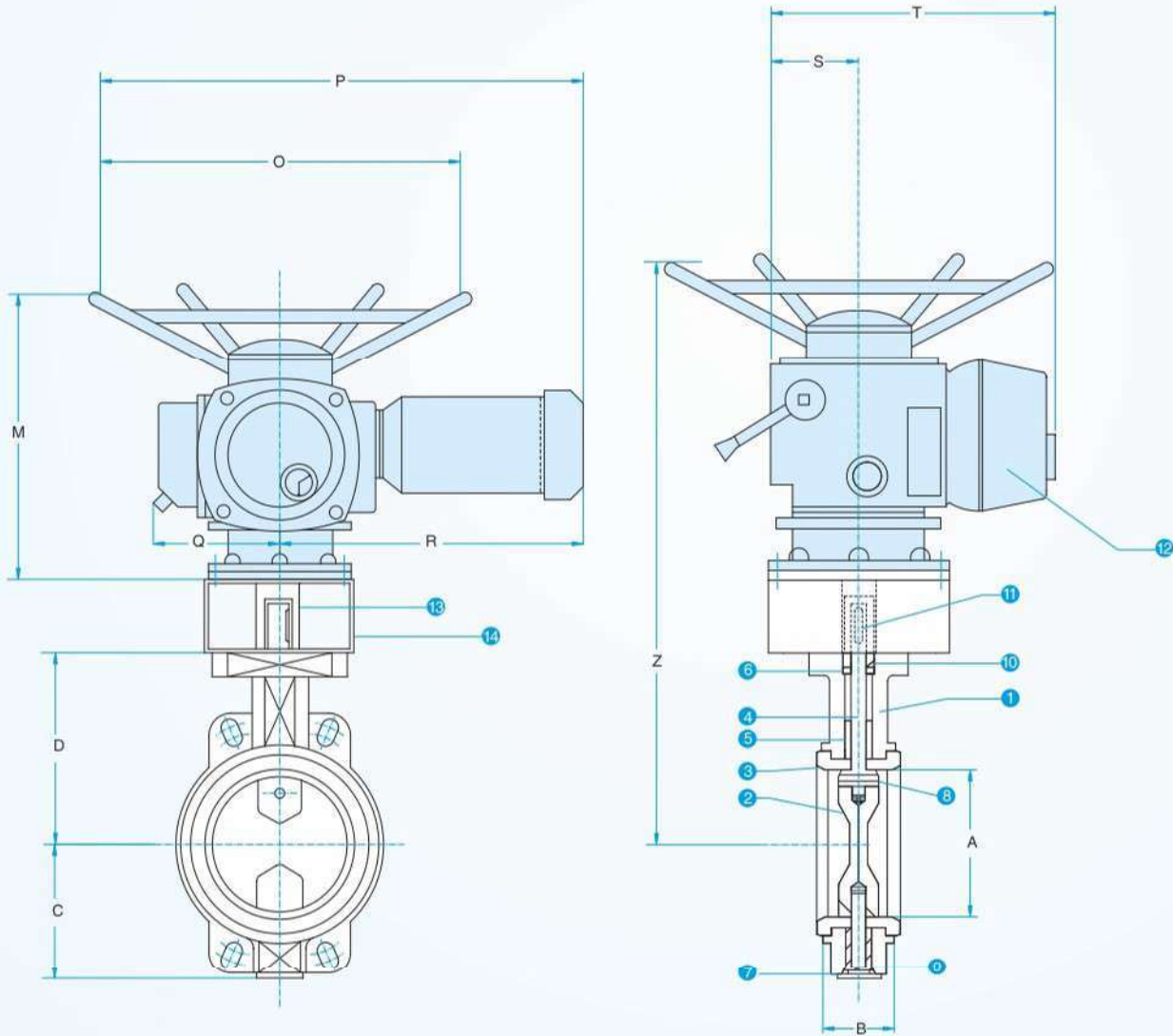

SL NO.	PART	MATERIAL
1	BODY	CAST IRON
2	DISC	SG IRON/SS304/316
3	BONDED SEAT	SLIM SEAL, NITRILE
4	SHAFT	SS410
5	BEARING	STEEL + PTFE
6	O-RING SHAFT	NITRILE
7	O-RING PLUG	NITRILE
8	TAPPER PIN	AISI316
9	PLUG	C-15
10	TOP BUSHING	POLYACETAL
11	KEY	EN8
12	ELECTRICAL ACTUATOR (SDTORK) MAKE	FOR DETAIL REFER MANUFACTURE
13	COUPLER	EN8
14	MOUNTING BRACKET	IS 2062

VALVE SIZE	MODEL NUMBER	A	B	C	D	M	O	P	Q	R	S	T	Z	WT. OF ASSY IN KGS.	Cv @		OPERATING TIME IN SEC
															60'	90'	
50	1250/PN16/50/SD-4000-20	50	43	73	113	340	485	685	225	440	85	400	589	65.2	65	130	3.5 TO 24
65	1250/PN16/65/SD-4000-20	65	46	80	121	340	485	685	225	440	85	400	615	66.85	120	240	3.5 TO 24
80	1250/PN16/80/SD-4000-20	80	46	88	128	340	485	685	225	440	85	400	629	69	160	320	3.5 TO 24
100	1250/PN16/100/SD-4000-20	100	52	104	146	340	485	685	225	440	85	400	681	74.45	280	560	3.5 TO 24
125	1250/PN16/125/SD-4000-20	125	56	116	158	340	485	685	225	440	85	400	711	79.4	430	860	3.5 TO 24
150	1250/PN16/150/SD-4000-20	150	56	138	174	340	485	685	225	440	85	400	745	89.3	640	1280	3.5 TO 24
200	1250/PN16/200/SD-4000-20	200	60	163	198	340	485	685	225	440	85	400	835	101.85	1200	2400	3.5 TO 24
250	1250/PN16/250/SD-4000-20	250	68	203	245	450	485	685	225	440	85	400	1050	143.7	1850	3700	11 TO 75

2-way Butterfly Valve – PN16 Rating With

Three Phase Electrical Actuator **SUDE**

1250

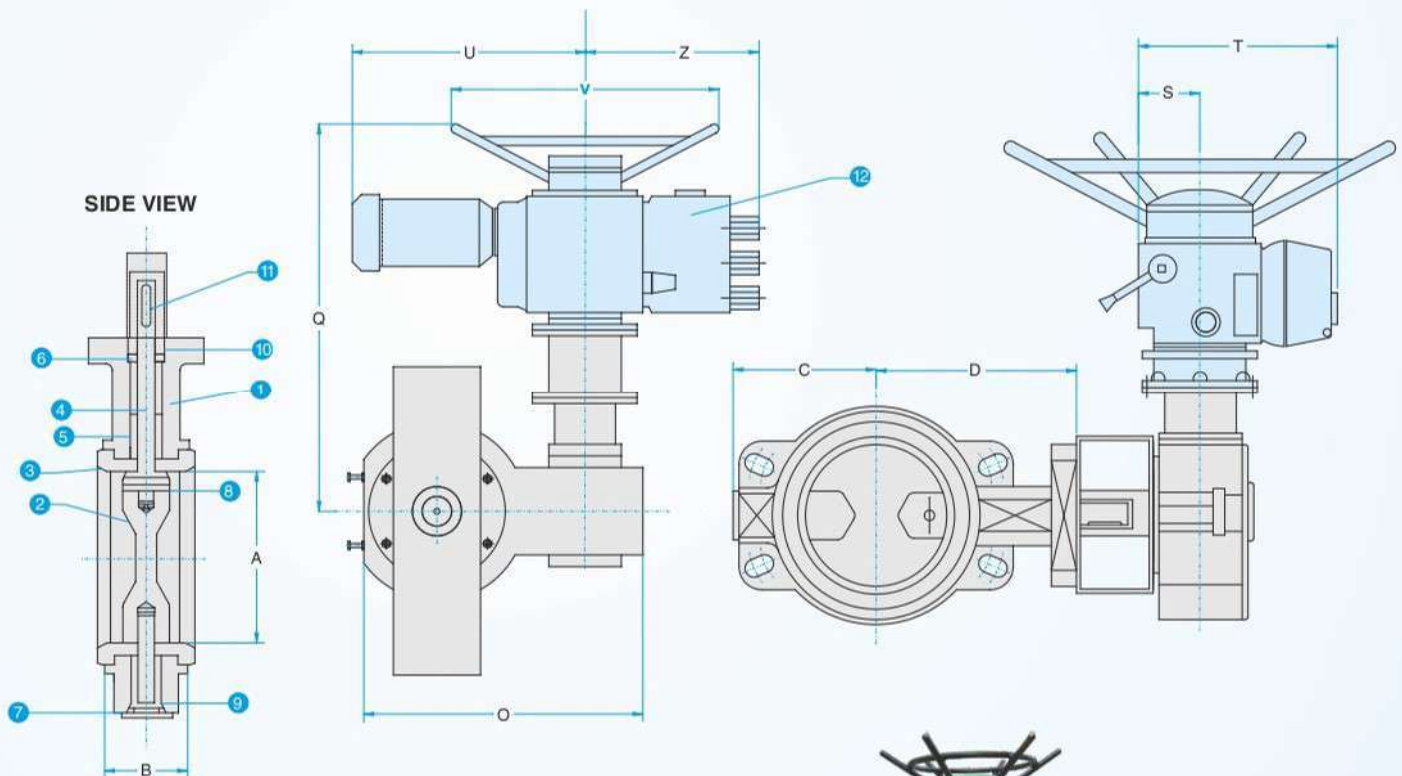

SL NO.	PART	MATERIAL
1	BODY	CAST IRON
2	DISC	SG IRON/SS304/316
3	BONDED SEAT	SLIM SEAL, NITRILE
4	SHAFT	SS410
5	BEARING	STEEL + PTFE
6	O-RING SHAFT	NITRILE
7	O-RING PLUG	NITRILE
8	TAPPER PIN	AISI316
9	PLUG	C-15
10	TOP BUSHING	POLYACETAL
11	KEY	EN8
12	ELECTRICAL ACTUATOR (SDTORK) MAKE	FOR DETAIL REFER MANUFACTURE



VALVE SIZE	MODEL NUMBER	A	B	C	D	E	O	Q	S	U	V	Z	T	WT. OF ASSY IN KGS.	Cv @		OPERATING TIME IN SEC
															60°	90°	
300	1250/PN 16/300/SD-4000-08-WG40	300	78	272	310	478	165	450	85	440	485	270	400	108	2700	5400	1.6 TO 60
350	1250/PN 16/350/SD-4000-08-WG40	350	78	342	318	486	165	450	85	440	485	270	400	193.7	3300	6600	1.6 TO 60
400	1250/PN 16/400/SD-4000-20-WG60	400	102	377	370	538	235	580	85	440	485	270	400	301.2	4400	8800	7.5 TO 94
450	1250/PN 16/450/SD-4000-20-WG60	450	114	447	410	608	235	580	85	440	485	270	400	338	6250	12500	7.5 TO 94
500	1250/PN16/500/SD-4000-20-WG135	500	127	477	440	638	348	700	85	440	485	270	400	441.1	6900	13800	17 TO 200
600	1250/PN16/600/SD-4000-20-WG135	600	154	547	500	728	348	700	85	440	485	270	400	567	10000	20000	17 TO 200

NOTE : TECHNICAL SPECIFICATIONS, DETAILS & DIMENSIONS ARE SUBJECT TO CHANGE WITHOUT PRIOR NOTICE.
DIMENSIONS IN THE TABLE ARE APPROXIMATE SUBJECT TO FINAL CONFIRMATION BY SUDE.

SUDE[®]

SUDE ENGINEERING CORPORATION

Registered Office / Works :

Shop No. 1106, 10th Main Road, R.P.C. Layout,
Near R.P.C. Layout Bus Stop, Hampinagar,
Bangalore 560 104. (Old Pin 560040) Karnataka, India

Tel. : +91 80 2330 2145 / 2314 1104 / 2340 2297

Fax : +91 80 2330 5729

Pune Office / Works :

Gat No. 94/2, Plot No.1, Alandi Markal Road,
Village - Dhanore, Tal - Khed, Pune 412105.
Maharashtra, India

Tel. : +91 9762719689, 9762719690